









COMPACT PACKAGE SHUNT-DIODE ZENER BARRIER



μZ600 Key Features

Approvals

AUTHORITY	CERTIFICATE/FILE No.	STANDARD	APPROVED FOR
	CESI 02 ATEX 136	EN 50.014 EN 50.020 EN 50.284	 II (1) G [EEx ia] IIC
 CSA	1433346	C22.2 No. 157 C22.2 No. 213 E60079 - 0 E60079 - 11 E60079 - 15	Cl. I, Div. 1; Cl. II, Div. 1; Cl. III Cl. I, Div. 2 Cl. I, Zone 2 Ex nA [ia] IIC; T4
 GOST	POCC IT. ГБ05: В00972	GOST P51330.10-99	[Ex ia] IIC
 FM	J.I.4DOA4.AX	Cl. No. 3600 Cl. No. 3610 Cl. No. 3611	Cl. I, Div. 1; Cl. II, Div. 1; Cl. III Cl. I, Div. 2 Cl. I, Zone 2 AEx nA [ia] IIC; T4
 SA **	AUS EX 2391X	SAA 2380.1 SAA 2380.7	Ex (ia) IIC

** Except μz641+ 641- 666ac 664ac.

Pepperl+Fuchs Elcon continually improves product development. Therefore specifications may change without notice.

Simple to Wire, less Time, low Costs

Three terminals are provided on both the safe and hazardous sides of the μZ600 barrier to make connection into the circuit simple and straightforward. This simple connection method even facilitates the cable screens and shields. Clear and convenient tagging is available on the top face of each barrier without requiring clumsy additional components.

Simple Selection, Easy to Use

μZ600 Series are “Shunt-diode” safety barriers and are used to interface control room equipment with devices or instrumentation in Hazardous Locations. These barriers use the protection technique of Intrinsic Safety to overcome the dangers posed by the presence of explosive atmospheres. The models of this series have been carefully defined to meet all the normal signal interfacing requirements of a process plant and to make selection of the appropriate item very simple. Making the choice and use of the barrier easier, from a small number of general purpose models, helps to reduce the stocks held by the user while improving availability from the supplier. Special applications can also be accommodated through discussion with our specialists.

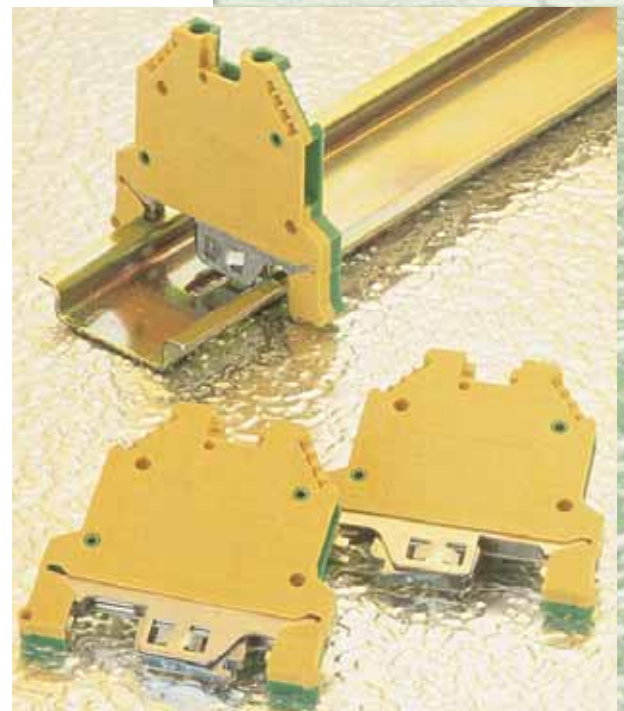

Simple to Maintain and Commission

There is no need for additional conventional terminals in the field wiring when using **μZ600** since the **REPLACEABLE FUSE** also provides a convenient “knife-edge” disconnect function. The circuit loop can be “opened”, thus, leaving the wiring securely in place to simplify the validation of the installation and the testing of the circuit.

Simple Protection, Readily Available

With ordinary safety barriers, a circuit is often overloaded during installation or commissioning. As a result, the safety fuse is ruptured and the entire barrier must be removed from its mounting and replaced. With the **μZ600** an **ADDITIONAL FUSE** for each channel, external to the safety component, is used to protect the circuit against the effects of overload conditions. This secondary 5 x 20 mm standard fuse is replaceable without removing the barrier or disconnecting the wires. Most of models use the same fuse value which reduces the number of required spares.

Tag holder

Provided on the front of every module.

12.5 mm (1/2") wide

High density, 80 barriers/meter of DIN rail (24/Ft).

Integral connection for cable screens/shields 4 mm² (10 AWG)

Simple to Mount, Secure Protection

The **μZ600** are easy to install into your instrumentation system without the need for custom tools or special mounting hardware - just clip them onto a **DIN RAIL**.

This simple operation not only secures them mechanically but also provides the connection to ground for the barrier without having to make a separate connection for each one.

Mounts and Earths/Grounds by clipping on-to Standard DIN Rail

Simple mounting, secure protection.

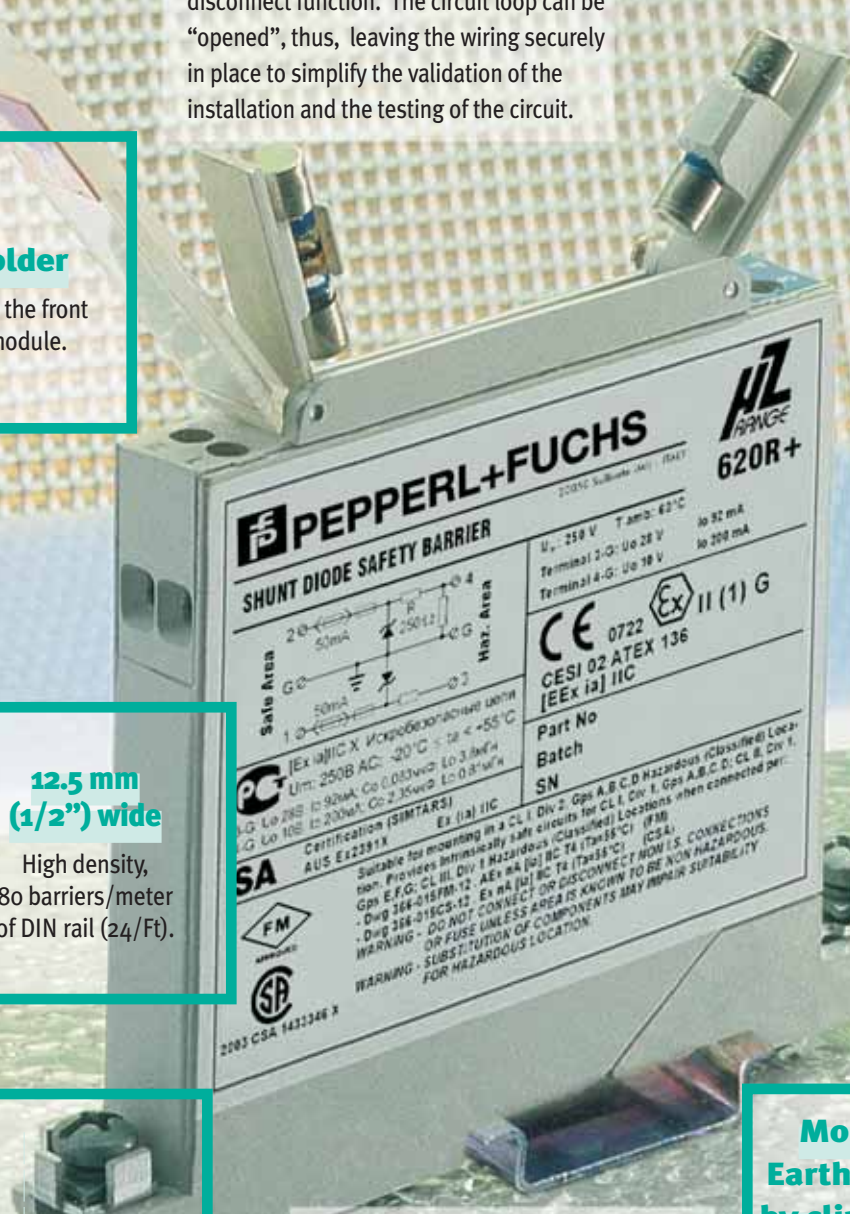

μZ600 Applications, the Intrinsic Safety Leaders

SAFE AREA

HAZARDOUS AREA

Zone 0, 1, 2

US Div. 1, 2

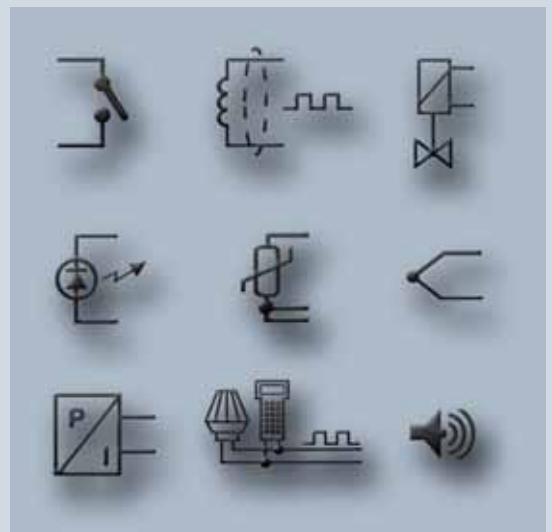
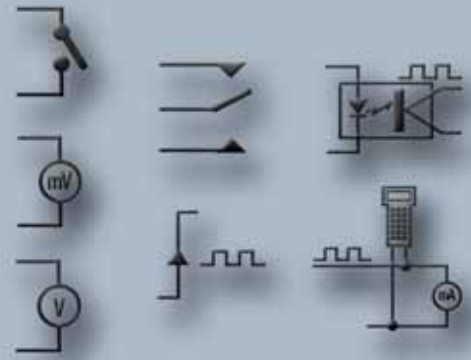

System description and applications

- Each **μZ600** barrier channel is essentially a fuse-protected, energy-diverting circuit where zener diodes limit voltage and series connected resistors limit current in Hazardous Location circuits.
- The amount of energy transferred to the Hazardous Location is limited to a safe level incapable of igniting the explosive atmosphere but in normal operating conditions the barriers pass electrical signals in both directions without shunting them. Thus, Hazardous Location wiring and equipment are protected against normal and abnormal circumstances so maintenance and calibration can be performed without particular precautions.
- **μZ600 Series** barriers have been designed to meet the majority of intrinsic safety applications so that “simple” apparatus, such as thermocouples, resistive sensors, switches or “Intrinsically Safe” apparatus, for example 2-wire transmitters, I/P converters, solenoid valves can be easily interfaced.
- Housed in a small plastic enclosure, **μZ600 Series** can be mounted side-by-side on a standard top hat 35 mm DIN rail and their compact dimensions allows very high density barrier installations to be obtained. The mounting clamp of the barrier also provides the electrical connection to the protective earth or ground, without requiring the use of separate conductors for each barrier, greatly simplifying installation.
- The low of height of the barrier, allows the **μZ600** to be mounted in small instrument and termination enclosures. Each channel of **μZ600** has an additional replaceable fuse to protect the barrier in case of voltage surge or faulty connection, giving a considerable cost saving over conventional unprotected barriers. This replaceable fuse also provides a convenient means of disconnecting or open-circuiting the instrument loop without interfering with the wiring, making commissioning and maintenance operations much easier.
- **μZ600 Series** barriers are designed for approval worldwide for all gases and all Zones/Divisions to make them suitable for installation everywhere.

μZ600 Product Range and Electrical Specification

Model	Polarity			Safety Description				R end to end	V wkg	V max	Fuse Rating	
	+	-	ac	V	Ω	mA	W	Ω	V	V	int. mA	ext. mA
μZ610			Circ. 9	13	1485	9	0.03	1544	10.5	11.5	63	50
				13	1485	9	0.03	1544	10.5	11.5	63	50
μZ620	Circ. 9			28	305	92	0.64	341	26	26.5	63	50
				10	50	200	0.50	80	8	8.5	63	50
μZ620R	Circ. 4			28	305	92	0.64	341	26	26.5	63	50
				10	50	200	0.50	80	8	8.5	63	50
μZ623		Circ. 5		26	305	86	0.56	341	22	26.5	63	50
				20	386	51	0.26	423	16.5	17	63	50
μZ630	Circ. 3	Circ. 7		28	305	92	0.64	341	26	26.5	63	50
				28	Diode	-	-	1.8 V @ 20 mA	26	26.5	63	50
μZ631	Circ. 3			28	255	110	0.77	289	26	26.5	63	50
				28	Diode	-	-	1.8 V @ 20 mA	26	26.5	63	50
μZ640			Circ. 9	15.5	99	157	0.61	130	12	12.5	63	50
				15.5	99	157	0.61	130	12	12.5	63	50
μZ641	Circ. 2	Circ. 6		15.5	99	157	0.61	113	12.5	13.5	125	100
μZ650	Circ. 1			21	148	142	0.75	180	17	18.5	63	50
				21	148	142	0.75	180	17	18.5	63	50
μZ660			Circ. 9	9	74	122	0.28	105	6	7	63	50
				9	74	122	0.28	105	6	7	63	50
μZ664			Circ. 9	13	990	14	0.05	1039	10.5	11.5	63	50
				13	990	14	0.05	1039	10.5	11.5	63	50
μZ666			Circ. 11	8	26.7	300	0.6	40	5.5	6.5	125	100
				8	26.7	300	0.6	40	5.5	6.5	125	100
μZ667			Circ. 9	18	123	147	0.67	155	14	15	63	50
				18	123	147	0.67	155	14	15	63	50
μZ670			Circ. 10	4.3	10.8	339	0.43	18.2 ± 0.1	0.5 @ 1 μA	2.5	125	-
				4.3	10.8	339	0.43	18.2 ± 0.1	0.5 @ 1 μA	2.5	125	-
μZ680	Circ. 1	Circ. 5		28	305	92	0.65	341	26	26.5	63	50
				28	305	92	0.65	341	26	26.5	63	50
μZ681	Circ. 2	Circ. 6		28	305	92	0.65	341	26	26.5	63	50
μZ690			Circ. 9	13	74	176	0.58	105	10.5	11.5	63	50
				13	74	176	0.58	105	10.5	11.5	63	50

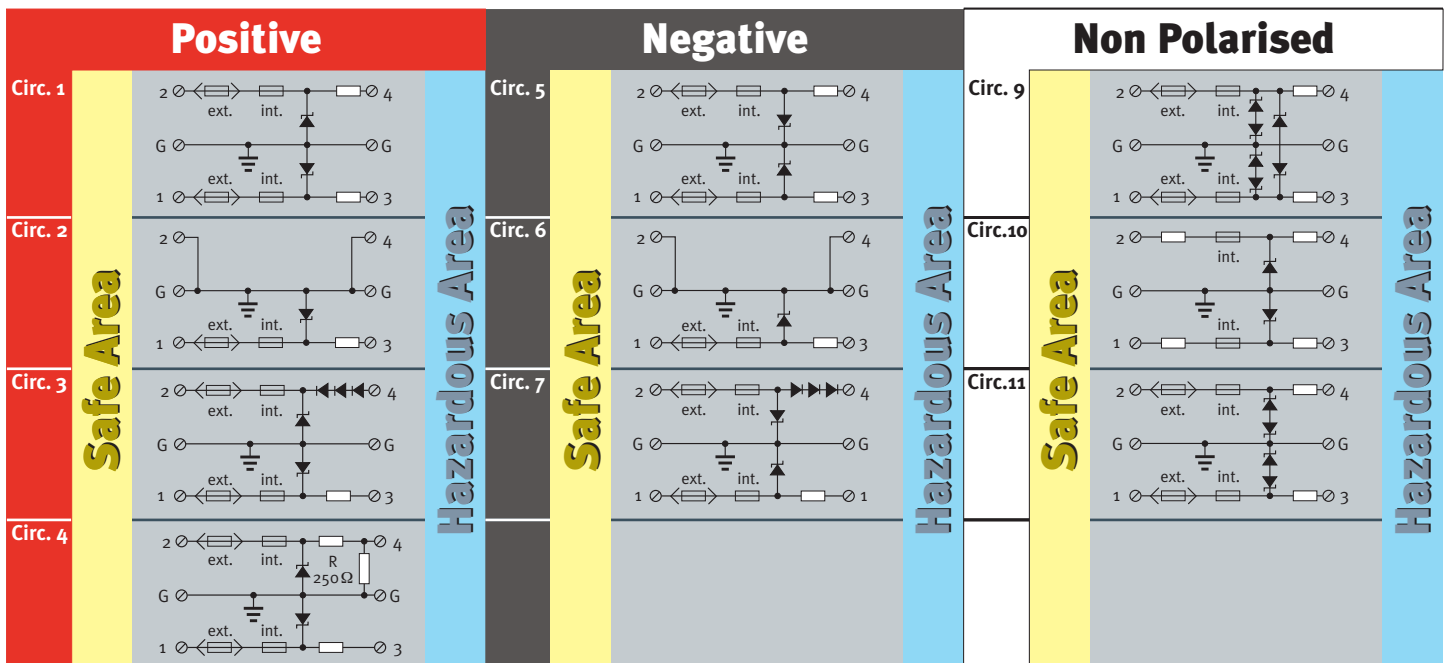

μZ600 Technical and Environmental Specification

Terminations: Two terminals on both sides to accommodate conductors up to 2.5 mm² (12 AWG).

Hazardous Area terminals are identified as blue.

Two terminals for grounding of cable screens/shields, up to 4 mm² (10 AWG).

Operating temperature range: -20 to 55°C (-4 to 131°F).

Storage temperature range: -40 to 75°C (-40 to 167°F).

Humidity: 10 to 90°C RH non condensing.

Weight: 130 gms.

Color coding of barrier top label

Red: positive polarity (+).

Black: negative polarity (-).

White: non-polarized (ac).

Mounting and earthing/grounding: Clamp directly onto symmetrical 35 mm rail to DIN 46277, EN50022.

Fuse carrier & loop disconnect: Each barrier channel has a safety fuse (int.) and a replaceable loop-protection fuse (ext.) The replaceable items are standard 5x20 mm fuses. Fuse carriers latch in open position to provide a loop disconnect function.

Electromagnetic compatibility: Conform to EN61326.

Terminology

Polarity: The symbols “+” or “-” or “ac” indicate positive, negative or non-polarized barriers and refer to the voltage of the specific polarity with respect to ground that can be passed by the barrier.

V max: The maximum voltage that can be continuously applied between the non Hazardous Area terminals and ground at 25°C, with the Hazardous Area terminals open and without blowing the fuse. For “ac” non-polarized barriers, the value is considered maximum peak voltage not rms.

V working (Vwkg): The maximum voltage that can be applied between the non Hazardous Area terminals and ground at 25°C, with the Hazardous Area terminals open and a specified leakage current of 10 μA. For “ac” non-polarized barriers, the value is considered maximum peak voltage not rms.

R end to end max.: The maximum resistance measured between the two ends of each channel. For diode return channels, the maximum voltage drop is quoted.

Order Information

P/N 124841	μZ 610ac
P/N 124842	μZ 620+
P/N 124843	μZ 620R+
P/N 124844	μZ 623-
P/N 124846	μZ 630+
P/N 124845	μZ 630-
P/N 124847	μZ 631+
P/N 124848	μZ 640ac
P/N 124850	μZ 641+
P/N 124849	μZ 641-
P/N 124851	μZ 650+
P/N 124852	μZ 660ac
P/N 124853	μZ 664ac
P/N 124854	μZ 666ac
P/N 124855	μZ 667ac
P/N 124856	μZ 670ac
P/N 124858	μZ 680+
P/N 124857	μZ 680-
P/N 124860	μZ 681+
P/N 124859	μZ 681-
P/N 124861	μZ 690ac

μZ600 Accessories

P/N 467738	PLTDIN
P/N 467731	ISP10
P/N 467227	GCLP600
P/N 466898	FUSA650
P/N 190967	FUSA6100
P/N 469535	TSHT600

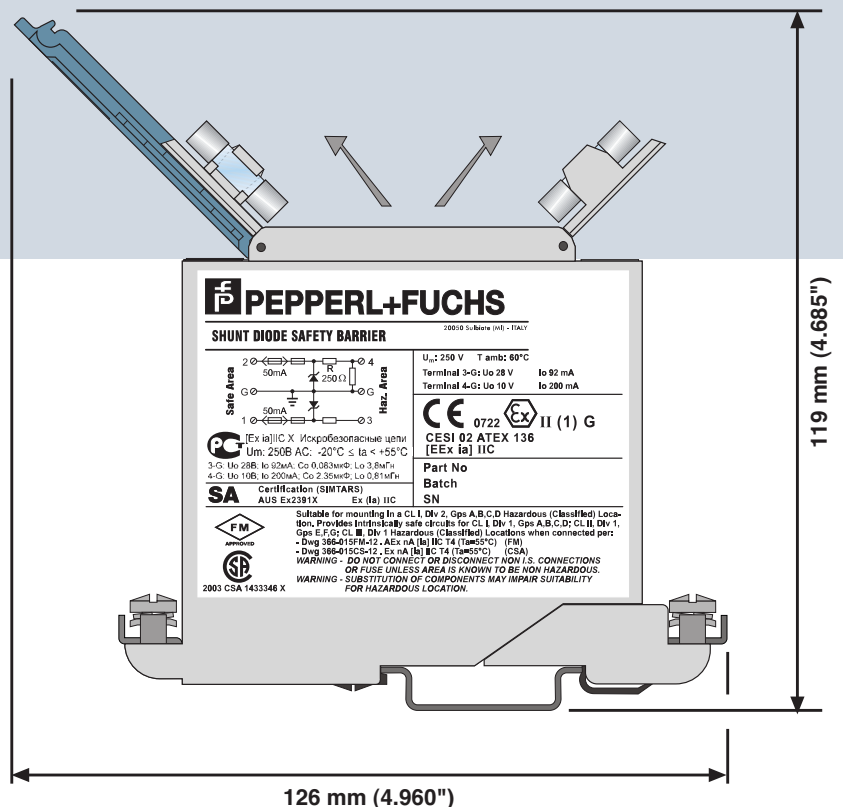

Accessories

PLTDIN Symmetrical top hat mounting rail
35 mm DIN 46277 Nickel plated 1 m length.

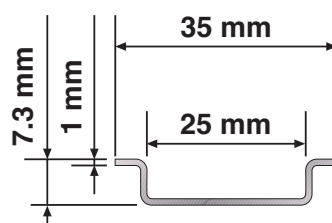

ISP10 Rail Insulating spacer.

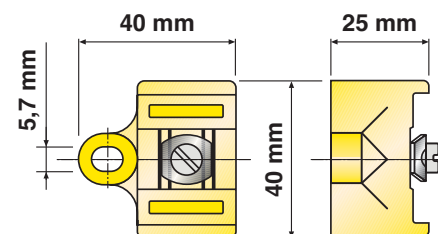

µZ600 Installation and Accessories

Installation and Grounding

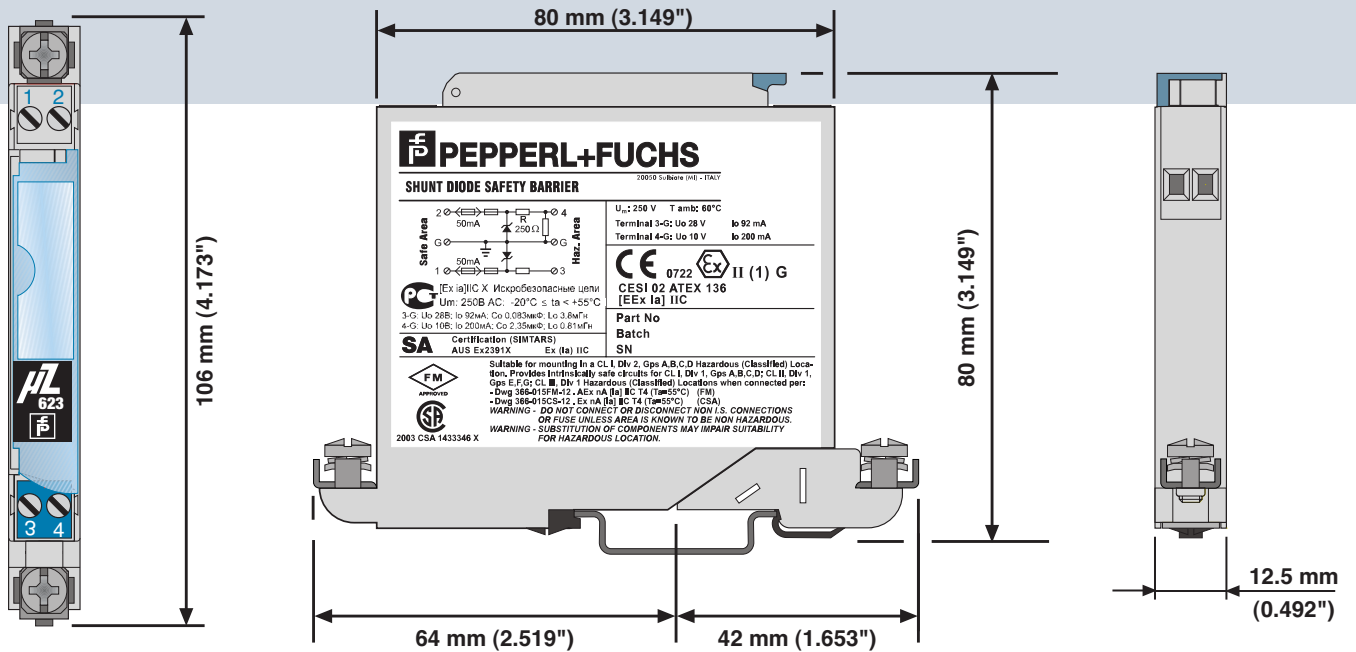
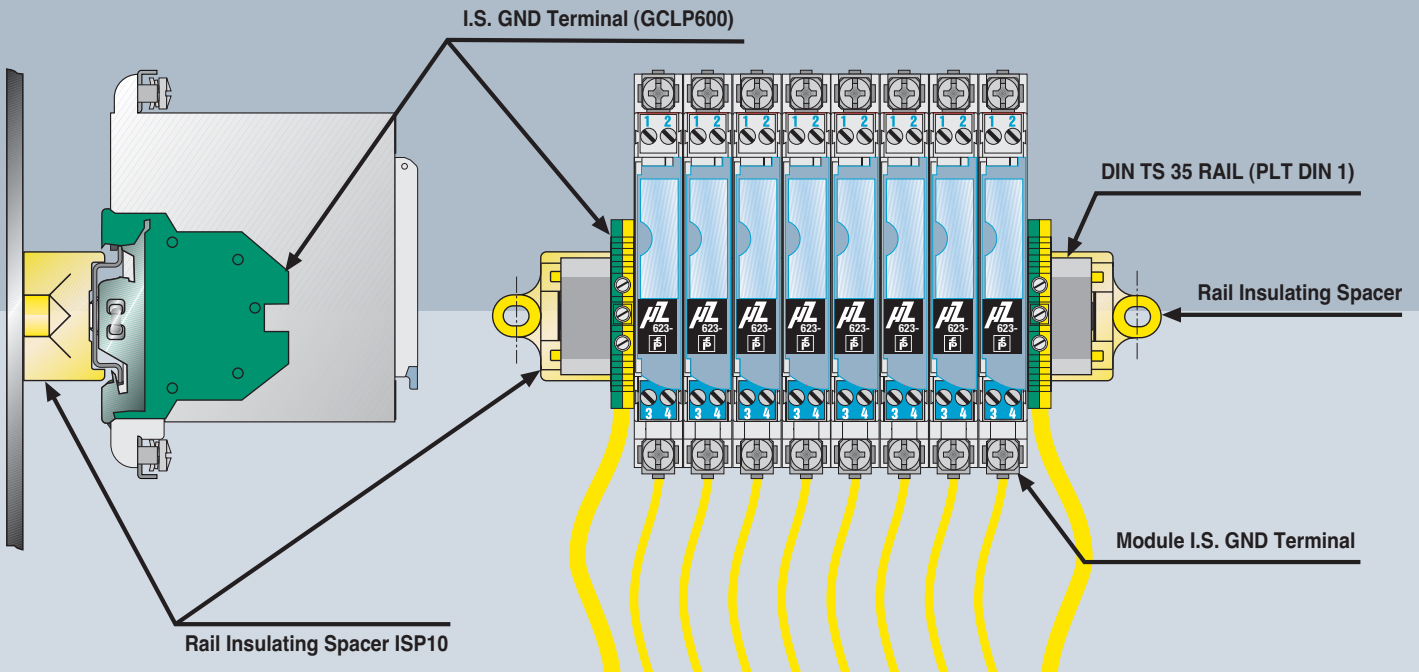

GCLP600 Earth/ground clamp for 35 mm DIN rail. For ground wires up to 4 mm² (10 AWG).

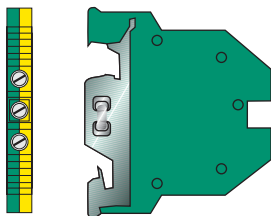

FUSA650 Replacement glass fuses, 50 mA, 5x20 standard, pack of 10.

FUSA6100 Replacement glass fuses, 100 mA, 5x20 standard, pack of 10.



TSHT600 Sheet of tagging labels, perforated, for typing, format DIN A4 (130 tag. each).

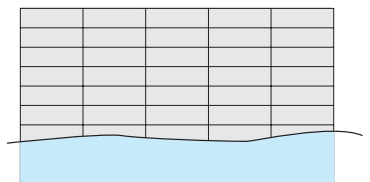



PROCESS AUTOMATION

For half a century Pepperl+Fuchs has continually provided new impetus to the world of automation. We develop, manufacture and market electronic sensors and interface modules through our worldwide network. Our global presence and highly flexible production and service organisations enable us to offer you complete individual solutions – right where you need us! We know what we are talking about – because today Pepperl+Fuchs is the company with the largest selection of industrial sensors technology in the World – serving a very broad spectrum of applications. **Our signals move the World.**



Worldwide Headquarters

Pepperl+Fuchs GmbH · Königsberger Allee 87
68307 Mannheim · Germany
Tel. +49 621 776-0 · Fax +49 621 776-1000
e-mail: pa-info@de.pepperl-fuchs.com

USA Headquarters

Pepperl+Fuchs Inc. · 1600 Enterprise Parkway
Twinsburg, Ohio 44087 · USA
Tel. +1 330 4253555 · Fax +1 330 4254607
e-mail: sales@us.pepperl-fuchs.com

Asia Pacific Headquarters

Pepperl+Fuchs Pte Ltd. · P+F Building
18 Ayer Rajah Crescent · Singapore 139942
Company Registration No. 199003130E
Tel. +65 67799091 · Fax +65 68731637
e-mail: sales@sg.pepperl-fuchs.com

South and East Europe Headquarters

Pepperl+Fuchs Elcon Srl
via delle Arti e Mestieri, 4
20050 Sulbiate (Mi) · Italy
Tel. ++39 039 6292 1 · Fax ++39 039 6292 240
e-mail: pa@it.pepperl-fuchs.com
www.pfelcon.it

www.pepperl-fuchs.com

 **PEPPERL+FUCHS**