

MUX2700 HART® Multiplexer



Application

The Mux2700 HART® Multiplexer provides 32 signal channels for connection to "Smart" transmitters or control devices supporting digital communication according to the HART® standard. Alternatively up to 16 HART® only (i.e. no 4-20 mA signal) devices can be connected to each channel in multidrop configuration. Full three-port isolation is included and each input channel has dual capacitor isolation for freedom of loop connection. The module acts as a gateway between a workstation - typically a PC with suitable PAM software - and the field instrumentation. Each Mux2700 is networked simply by connecting the high-speed RS485 output in multi-drop configuration. The Mux2700 interrogates each field device, under the supervision of the workstation, retrieving information for storage in its internal database, which can then be accessed at ease.

Specification

DC Supply

CURRENT CONSUMPTION: 28 mA at 24 V typical, RS485 quiescent.
POWER DISSIPATION: 0.7 W at 24 V.

Signal Channels

NUMBER OF CHANNELS: 32.
DC ISOLATION: dual capacitor for each channel.
COMMON MODE VOLTAGE: up to 30 V.
DIFFERENTIAL MODE CLAMPING: ± 5.2 V (for transient or ac signals).
COMMON MODE CLAMPING: ± 10 V (for transient or ac signals).
RECEIVE SIGNAL RANGE: 0.12 Vpp < signal < 1.5 Vpp.
RECEIVE IMPEDANCE: > 5000 ohms.
CARRIER DETECT LEVEL: signal > 0.12 Vpp, CD asserted. Signal < 0.08 Vpp, CD not asserted.
TRANSMIT AMPLITUDE: 200Ω load - 0.43 Vpp < signal < 0.49 Vpp.
 500Ω load - 1.1 Vpp < signal < 1.2 Vpp.
DEVICE TYPE: secondary device.
IMPEDANCE LEVEL: high impedance device.
DATA LINK TYPE: HART® primary or secondary.
FIELD MULTI-DROP SUPPORT: option available upon request.
NOTE: the Mux2700 generally complies with the HART® FSK Physical Layer Specification Rev. 8.0 available from the HART® Communication Foundation. HART® is a registered trademark of the HART® Communication Foundation.

Galvanic Isolation Specifications

24 V SUPPLY/FIELD CHANNELS: 1400 Vac, rms.
24 V SUPPLY /RS-485 SERIAL PORT: 1400 Vac, rms.
RS-485 SERIAL PORT/FIELD CHANNELS: 500 Vac, rms.

Serial Port

LINE TYPE: RS-485, differential pair plus ground.
LINE SPEED: 9600 or 19200 Baud, switch selectable.
LINE TOPOLOGY: multi-point, master-slave connection.
UNIT ADDRESS: 1 to 31, switch selectable.

Selector Port

SW1-SW5: Unit slave address. **SW6-SW7:** Baud rate. **SW8:** Test mode.

LED Indicators:

Power ON (green). HART® transmission (yellow). Fault (red).

- 32 channel input.
- RS485 serial data connection.
- Communicates with HART® Transmitters and HART® I/P Valve positioners.
- No complicated master/slave configuration.
- Channel to channel isolation.

SAFE AREA OR HAZARDOUS AREA ZONE 2

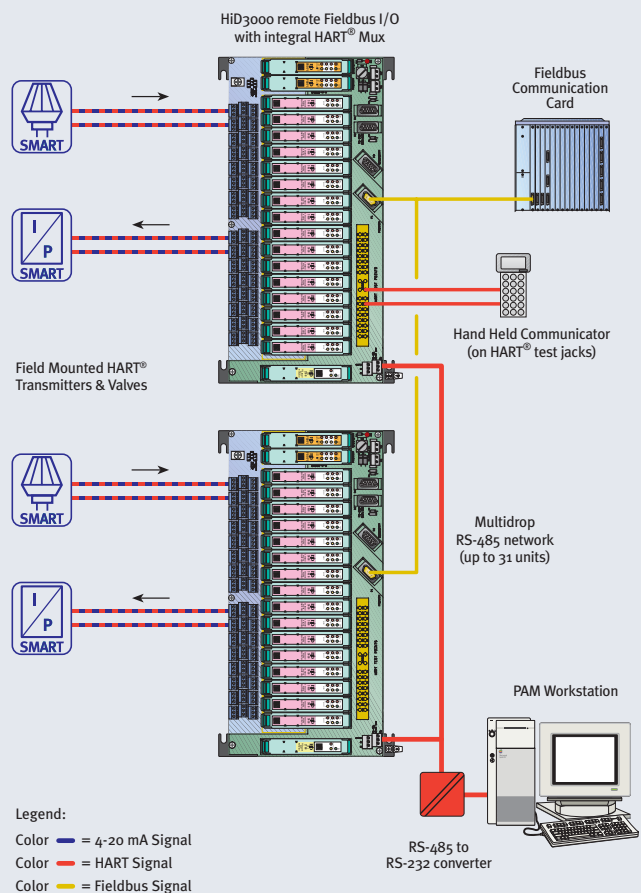
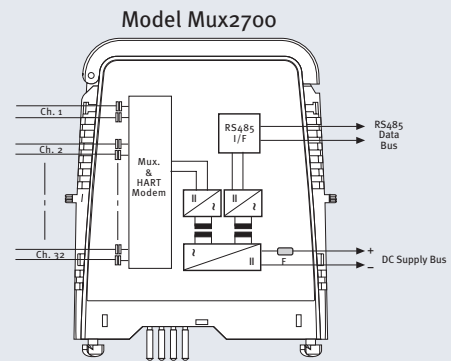

MUX2700 Design Features

Special Design Features

High Specification Front end Design

Two Decoupling Capacitors are provided, one for each signal connection.

Both + Ve (positive) & - Ve (negative) signal wires are consequently decoupled from DC signal.

Only the high frequency digital HART® protocol signal passes through to the internal Multiplexer circuitry.

Failure of any capacitor from either a short circuit or open circuit means that availability of 4-20 mA control signal will not be affected.

- No DC loading of 4-20 mA control signal.
- No single point of failure.
- High Noise Immunity.

The max 30 Vdc input voltage (specified between all terminals, both belonging to the same channel or not) makes it possible to connect any MUX terminal to whatever voltage level can be derived from a 24 Vdc supply, +20% tolerance included.

Three-Port Isolation

Both the 24 V supply input and the RS-485 serial interface are isolated from the HART® section, i.e. from the HART® signals on the field devices.

Please refer to previous page the three-port isolation structure of the MUX2700.

Self Contained Architecture

Each Multiplexer module is a stand alone device containing all necessary hardware to communicate with up to 32 HART® protocol enabled Field Devices and a host PC via RS485.

- Fast Polling.
- One module design.
- RS485 direct from module.
- No communications bottleneck.
- Ideal for valve diagnostics.

Wide Software Compatibility

Fully compatible with Emerson AMS, ValveLink and other process management packages.

Additional compatibility extends to HART® OPC server software available from HCF (HART® Communication Foundation).

Allowing users to write dedicated applications for their specific needs. Fully tested, by all key PAM vendors.

Mux2700 Mounting Options

HiD3000 with Integrated HART® Mux2700

- Remote I/O for Safe and Hazardous Area Zone 2.
- Fully integrated Intrinsic Safety and HART® Mux.
- Replaces DCS, ESD or PLC I/O Cards.
- Total integrated solution with minimal interconnections.

Intrinsic Safety and Remote I/O System

